

80W DC/DC POWER SUPPLY FOR AUTOMOBILE

1 Function Description

DC/DC ATX power supply for automobile application, 12VDC input, +5V,+12V,+3.3V,-12V,+5VSB and PG (power good signal) outputs.

2 Operation Environment

Item	Unit	Minimum	Typical	Maximum	Test Conditon
Temperature	°C	-20		50	
RH	%RH	40		90	No Condensation

3 Technique Requirement

3.1 Input Characteristic

Item	Unit	Minimum	Typical	Maximum	Test Conditon
DC INPUT	Vdc		12		
Input Current	A		8		

3.2 Output Characteristic

3.2.1 Output Voltage Regulation

Output	Min. Load	Max. Load	Peak Load	Output Voltage range	Ripple (pk-pk) (rated load、20MHz limit) *
+5V	0.5A	5A		4.75~5.25V	50mV
+12V	0.3A	2A	4A	11.40~12.60V	120mV
+3.3V	0.5A	5A		3.14~3.55V	50mV
-12V	0A	0.1A		-11.0~-13.2V	120mV
+5VSB	0.1A	1.5A		4.75~5.25V	100mV

*: Need to add 47 μ F tantalum capacitor and 0.1 μ F high frequency capacitor on test point when testing.

3.2.2 Others Output Characteristics

Item	Unit	Minimum	Typical	Maximum	Test Conditon
Output Power	W		80		DC output power
Efficiency	%		94		Rated load
Turn on Overshoot	%			10	
Rise Time	ms		20		Output voltage up from 0% to 95%, rated load
Hold up Time	ms		2		Rated load

3.3 EMC Requirement

Item	Request	Standard	Judgement Grade
Conducted interference	CLASS B, 3dB margin	EN55022	Ensure system pass the CLASS B and have 3dB margin
Radiation interference	CLASS B, 3dB margin	EN55022	Ensure system pass the CLASS B and have 3dB margin

3.4 Protection Function

Item	Unit	Yes/No	Minimum	Typical	Maximum	Recovery Characteristic
Input inversion protection		Yes				
+5V OVP	V	Yes	5.8		6.8	Latched, need to re-apply DC input to recovery
+12V OVP	V	Yes	13.2		15.6	Latched
+3.3V OVP	V	Yes	3.9		4.3	Latched
Short Circuit Protection (+5V,+12V,+3.3V)		Yes				Latched

4 Monitoring ,Signal Control

4.1 PG signal Sequence

Parameter	Value Request			Test Condition		Figure
	Name	Minimum	Typical	Maximum	Input voltage	
tp.G	100ms		500ms	12VDC	100%	
tp.F	0.5ms	1ms		12VDC	100%	
tr		5ns	50 μ s	12VDC	100%	
tf		500ns	10 μ s	12VDC	100%	

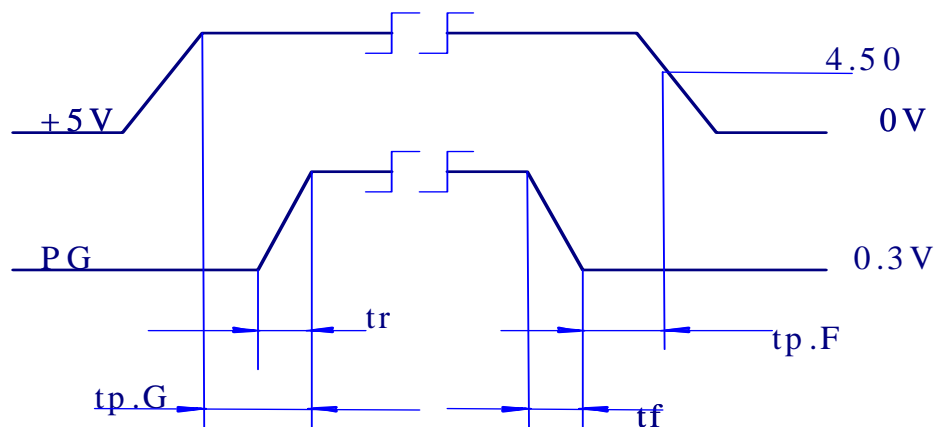
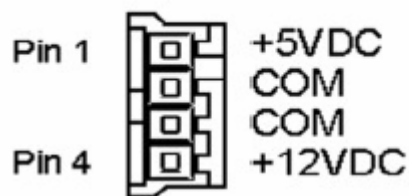
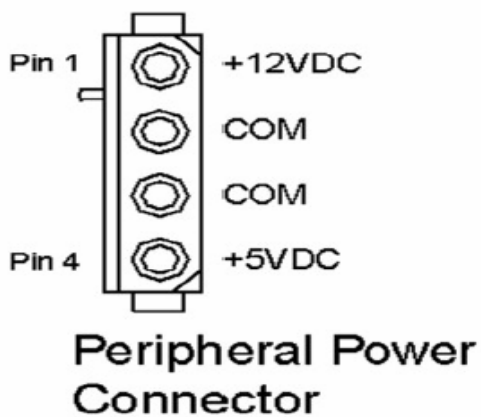
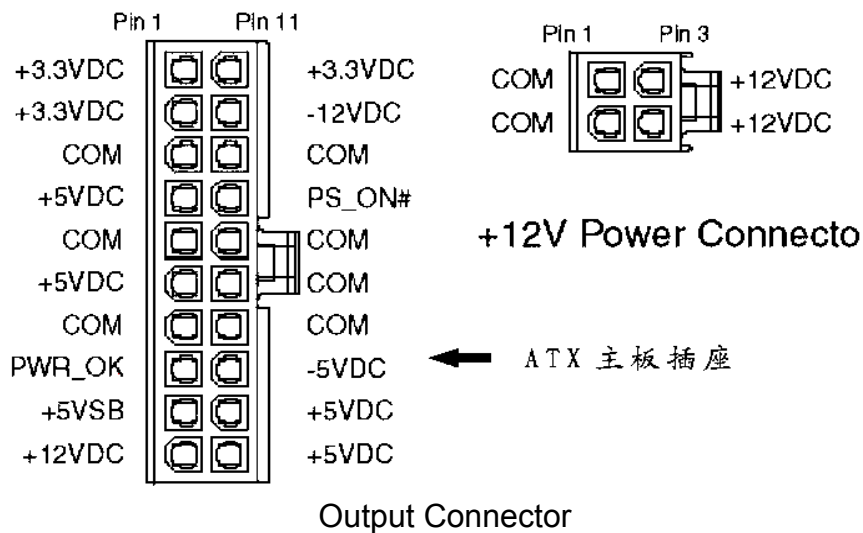

FIG1

5 Mechanical Requirement

5.1 Outline and Connection



Floppy Drive Power Connector

Output Connector

5.2 Dimension

