

150W DC/DC POWER SUPPLY FOR AUTOMOBILE

1 Function Description

DC/DC ATX power supply for automobile application, 6-30VDC input, +5V,+12V,+3.3V,-12V,+5VSB and PG (power good signal) outputs.

2 Operation Environment

Item	Unit	Minimum	Typical	Maximum	Test Conditon
Temperature	°C	-20		50	
RH	%RH	40		90	No Condensation

3 Technique Requirement

3.1 Input Characteristic

Item	Unit	Minimum	Typical	Maximum	Test Conditon
DC INPUT	Vdc	6	12/24	30	
Input Current	A		5/10		

3.2 Output Characteristic

3.2.1 Output Voltage Regulation

Output	Min. Load	Max. Load	Peak Load	Output Voltage range	Ripple (pk-pk) (rated load、20MHz limit) *
+5V	0.5A	10A		4.75~5.25V	50mV
+12V	0.3A	5A		11.40~12.60V	120mV
+3.3V	0.5A	10A		3.14~3.55V	50mV
-12V	0A	0.6A		-11.0~-13.2V	120mV
+5VSB	0.1A	2A		4.75~5.25V	100mV

*: Need to add 47 μ F tantalum capacitor and 0.1 μ F high frequency capacitor on test point when testing.

3.2.2 Others Output Characteristics

Item	Unit	Minimum	Typical	Maximum	Test Conditon
Output Power	W		150		DC output power
Efficiency	%		88		Rated load
Turn on Overshoot	%			10	
Rise Time	ms		20		Output voltage up from 0% to 95%, rated load
Hold up Time	ms		2		Rated load

3.3 EMC Requirement

Item	Request	Standard	Judgement Grade
Conducted interference	CLASS B, 3dB margin	EN55022	Ensure system pass the CLASS B and have 3dB margin
Radiation interference	CLASS B, 3dB margin	EN55022	Ensure system pass the CLASS B and have 3dB margin

3.4 Protection Function

Item	Unit	Yes/No	Minimum	Typical	Maximum	Recovery Characteristic
Input inversion protection		Yes				
+5V OVP	V	Yes	5.8		6.8	Latched, need to re-apply DC input to recovery
+12V OVP	V	Yes	13.2		15.6	Latched
+3.3V OVP	V	Yes	3.9		4.3	Latched
Short Circuit Protection (+5V,+12V,+3.3V)		Yes				Latched

4 Monitoring ,Signal Control

4.1 Process Sequence

Item	Name	Characteristic
1	Ignition (The Ignition signal controlled by the voltage signal from the key)	<ol style="list-style-type: none"> 1) Ignition=OFF, Nothing happens , waiting for Ignition signal ON. 2) Ignition=ON, wait for 3-4s, open +5VSB output, after another 1s the MCU sends an "ON" signal to the motherboard via the 2 wires connected to the motherboard's ON/OFF pins. The motherboard will turn ON and your system should start booting. 3) Ignition=ON , nothing happens , your computer will remain ON. 4) Ignition=OFF ,wait about 10s and then it turned motherboard OFF by sending a signal to the motherboard's ON/OFF switch. Your computer should turn off gracefully. During this time, power will still be available for your PC to perform shutdown. 5) Ignition=OFF after 10s. Power will still be provided for another 50s, long enough for most soft shutdown processes. In the event where the shutdown processes is hanging, power will be shutdown hard, turn off your computer's main power source to prevent battery drain. 6) Go back to step 1, until ignition is turned ON again.
2	Controlled motherboard signal (PS-ON)	PS-ON is to control motherboard ON/OFF switch for 'soft' start/stop sequence.. PS-ON is activated 5s after the ignition circuit is turned on and 10s after the ignition turned off.
3	Power good signal (PG)	<p>The PG signal comes from the No. pin8 of the 20pin output connector, it indicate the power supply working condition, this 'TTL' signal is the result of "AND" relationship with DC output and DC input voltage . On working condition, if the DC input voltage is well within it's operation range, then the PG signal is sent out (PG is in H logic) after 100-500ms delay. If the DC input voltage down and below to 11V, or the one of DC output voltage out of it's normal range, then send out Power Fall signal (that is: PG is in L logic). The Power Fall signal fall to below 0.3V, should have 1ms (at least) before the +5V output down to 4.5V,. And the PG signal's slop during the rise up and fall down</p> <p>Should be smooth and no any oscillation happened. PG signal should have the capacity to drive 6 standard TTL</p>

		loading. Following is the under voltage level of each output:										
		<table border="1"> <thead> <tr> <th>Output</th> <th>+5V</th> <th>+12V</th> <th>+3.3V</th> <th>-12V</th> </tr> </thead> <tbody> <tr> <td>UVP level</td> <td>+4.5V</td> <td>+10.8V</td> <td></td> <td>-10.4V</td> </tr> </tbody> </table>	Output	+5V	+12V	+3.3V	-12V	UVP level	+4.5V	+10.8V		-10.4V
Output	+5V	+12V	+3.3V	-12V								
UVP level	+4.5V	+10.8V		-10.4V								
4	Sleeping mode control (ON/OFF)	The ON/OFF signal comes from the No. pin14 of the 20pin output connector, is to control the power supply's working state. (Be active in 'L' level). If the ON/OFF signal is in floating, the power supply will have no output (except 5VSB) and in sleeping mode . The 5VSB should be within the range of 4.75-5.25V under 1.5A loading condition, and no any audible noise can be heard. If the ON/OFF signal is shorted to ground, the power supply will be in normal working condition and have normal output voltage.										
5	Battery Protection	The power supply will shutdown hard when the battery voltage below 11V, and the power supply will recovery ON when the battery voltage back and exceed 12V .										

6	Hand control	<p>The power output set by the jumper wire. when it's set in automation mode, the power supply will work according to the process of the item 1.</p> <p>When it's set to hand control mode, it controlled by external switch:</p> <ol style="list-style-type: none"> 1) Ignition=OFF, Nothing happens , waiting for Ignition signal ON。 2) Ignition=ON, wait for 3-4s, open +5VSB output, the power supply go into sleeping mode, waiting for switch ON/OFF. 3) Ignition=ON, press the switch button one time, sends an "ON" signal to the motherboard .The motherboard will turn ON and your system should start booting。 4) Ignition=ON, during power be in ON condition, press the switch button one time (<1s transient time). Nothing happens. 5) Ignition=ON, during power be in ON condition, press the switch button for 3-4s, then send an "OFF" signal to the motherboard, the power supply go into sleeping mode. 6) Ignition=OFF, during power be in ON condition, wait about 10s and then it turned motherboard OFF by sending a signal to the motherboard's ON/OFF switch. Your computer should turn off gracefully. During this time, Power will still be provided for another 50s, long enough for most soft shutdown processes. In the event where the shutdown processes is hanging, power will be shutdown hard, turn off your computer's main power source to prevent battery drain. 7) Ignition=OFF after 10s. during power be in OFF condition. Power will be shutdown include +5VSB output. 8) Go back to step 1, until ignition is turned ON again。
---	--------------	--

4.2 PG signal Sequence

Parameter	Value Request			Test Condition		Figure
	Name	Minimum	Typical	Maximum	Input voltage	
tp.G	100ms		500ms	Normal	Normal	FIG1
tp.F	0.5ms	1ms		24VDC	100%	FIG2

tr		5ns	50 μ s	24VDC	100%	FIG3
tf		500ns	10 μ s	24VDC	100%	FIG4

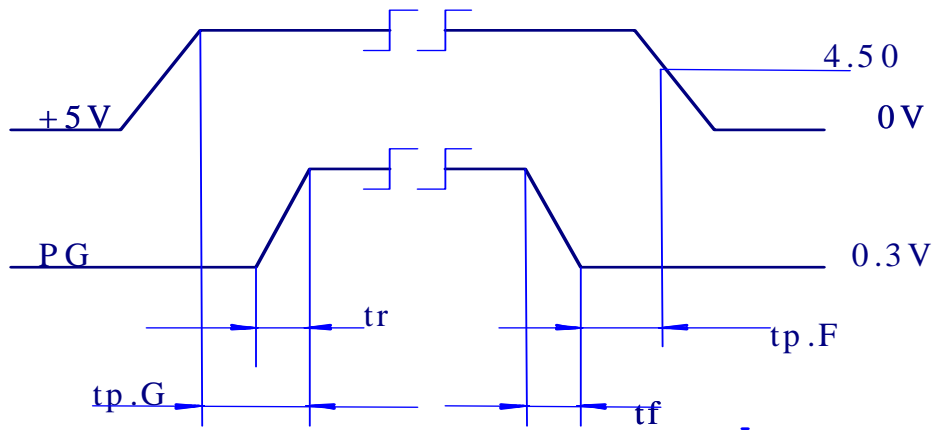
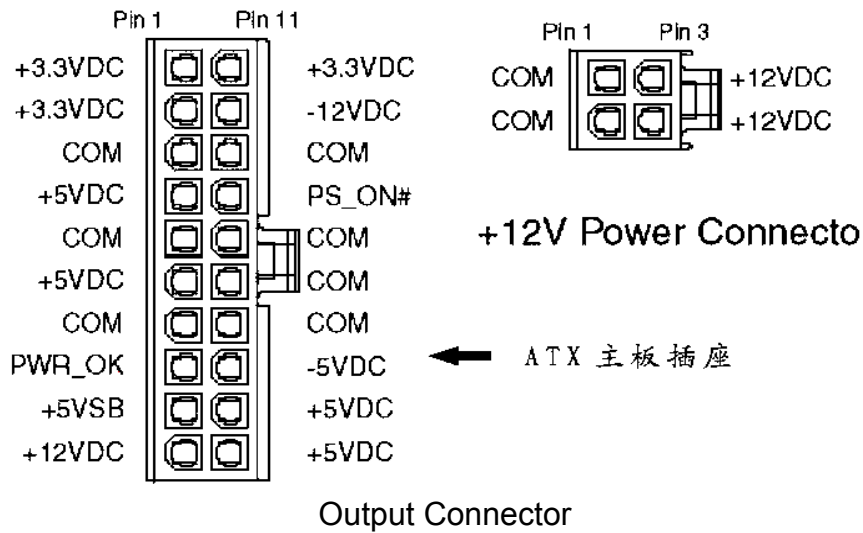
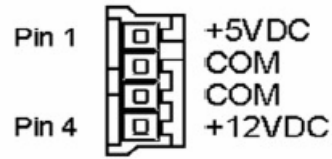
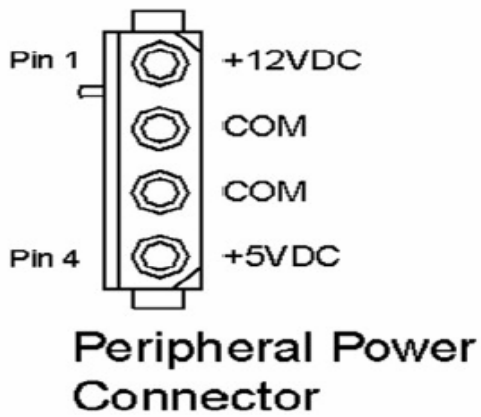

FIG1

5 Mechanical Requirement

5.1 Outline and Connection





Floppy Drive Power Connector

Output Connector

5.2 Dimension



Dimension: 160mmX45mmX28mm

5.3 Label

standard

6 Reliability Requirement

MTBF should exceed 100,000Hours under 80% loading, 25°C ambient

7 Package, Store and Traffic Requirement

Standard